

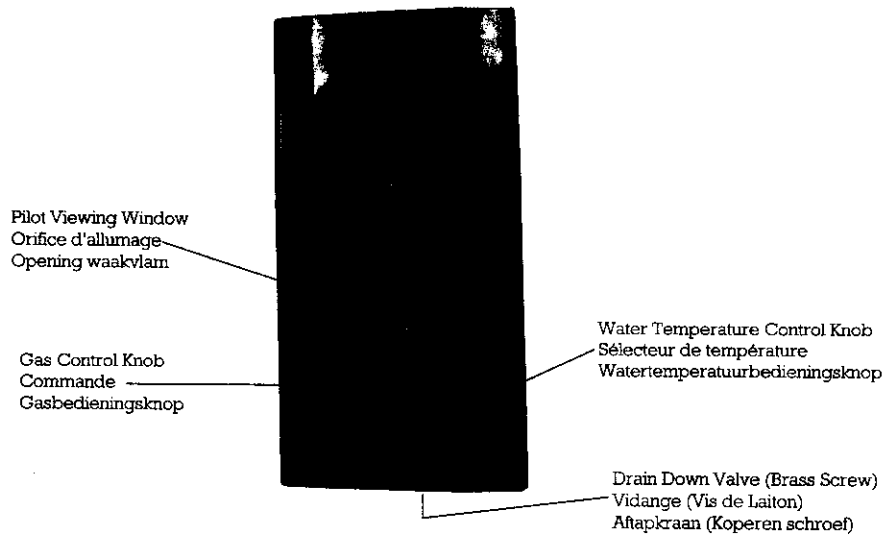

MORCO MODELS D-51B AND G111E



INDEX

A.- ENGLISH

A.1 INSTRUCTIONS FOR USES	
A.2 TECHNICAL INSTRUCTIONS FOR INSTALLATIONS ENGINEERS	
A.2.1 TECHNICAL INFORMATION	
A.2.2 INSTALLATION INSTRUCTIONS	
A.2.3 LOOKING AFTER THR APPLIANCE	
A.2.4 SYMBOLS	
A.2.5 WARRANTY	

B.- FRANCAIS

B.1 INSTRUCTIONS POUR L'UTILISATEUR	
B.2 INSTRUCTIONS TECHNIQUES POUR L'INSTALLATEURS	
B.2.1 DONNÉS TECHNIQUES	
B.2.2 NORMES D'INSTALLATION	
B.2.3 INSTRUCTIONS POUR LA MISE EN MARCHÉ	
B.2.4 MAINTENANCE	
B.2.5 SYMBOLES	
B.2.6 GARANTIE	

C.- NEDERLANDS

C.1 GEBRUIKSAANWIJZING	
C.2 TECHNISCHE INSTRUCTIES VOOR INSTALLATIE MONTEURS	
C.2.1 TECHNISCHE INFORMATIE	
C.2.2 INSTRUCTIES VOOR DE INSTALLATIE	
C.2.3 INSTRUCTIES VOOR HET BEDRIJESKLAAR MAKEN VAN DE GEISER	
C.2.4 ONDERHOUD	
C.2.5 SYMBOLEN	

MORCO MODELS D-51B AND G111E

INSTANTANEOUS MULTI-POINT WATER HEATER

FITTED WITH DRAUGHT DIVERTER

FOR NORMAL OPEN FLUED SYSTEM

THIS HEATER IS MANUFACTURED IN ACCORDANCE WITH EN 26

NOTE: THIS APPLIANCE IS ADJUSTED FOR USE ON LIQUEFIED PETROLEUM GAS ONLY (BUTANE AND PROPANE GAS)

USERS INSTRUCTIONS

TECHNICAL INSTRUCTIONS

BEFORE USING THIS APPLIANCE PLEASE READ THESE INSTRUCTIONS THOROUGHLY, ALWAYS RETAIN THE INSTRUCTIONS FOR FUTURE USE

GAS SAFETY (INSTALLATION AND USE) REGULATIONS 1994

IN THE INTEREST OF SAFETY, IT IS THE LAW THAT ALL GAS APPLIANCES ARE INSTALLED AND SERVICED BY A COMPETENT PERSON IN ACCORDANCE WITH THE ABOVE REGULATIONS, BUILDING REGULATIONS, CODES OF PRACTICE AND BYELAWS OF THE LOCAL WATER UNDERTAKING.

FAILURE TO COMPLY WITH THE REGULATIONS MAY LEAD TO PROSECUTION. IT IS IN YOUR INTERESTS AND THAT OF SAFETY THAT THE LAW IS COMPLIED WITH.

A.1.-INSTRUCTIONS FOR USERS

Technical instructions for use and maintenance

WARNING: Before use, this appliance must be installed and adjusted by a competent person according the technical instructions in this manual. No attempt must be made to adjust this appliance for use with other gases.

• LIGHTING THE PILOT

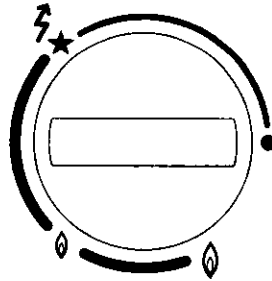

- Fully depress the control knob and turn it to the left from the ● position to the ★ position (pilot setting).
- The pilot light will come on during this operation due to the action of the piezoelectric spark igniter or electronic ignition.
- Hold this knob in this position for about 10 seconds.

If the pilot fails to light after having activated the piezoelectric spark igniter mechanism or electronic ignition, this means that there is air in the gas pipes. In this case, wait enough time for the pipes to be cleared of air, with the gas control knob at the pilot setting. ★ Where there are long gas pipe runs, it may take up to 3 minutes.

• PREPARING THE HEATER FOR USE

Once the pipes are free of air and the pilot is alight, and after waiting about 10 seconds for the safety valve mechanism to be activated, the appliance is ready for use. Turn the control knob anti-clockwise to a main burner position 🔥.

• GAS CONSUMPTION SELECTION

You can choose between two different types of operation, depending on what you are going to use the appliance for:

Economy setting

Turn the control knob to the 🔥 position.

Use this setting only when ambient temperature of water is high.

Full power setting (For normal use)

Turn the control knob to the 🔥 position.

• WATER TEMPERATURE SELECTION

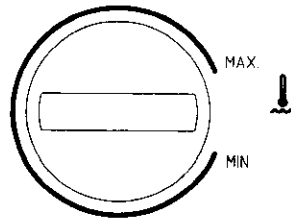

For either of the two types of operation selected, to adjust the hot water temperature turn the selector control to the right for hotter water and to the left for cooler water.

- Whatever the water temperature selected, it remains constant even if there are fluctuations in the mains water pressure, thanks to the action of the automatic water flow regulator.
- Never reduce the flow of hot water by using the appliance's water inlet stopcock. This stopcock should always be fully open.

• TURNING OFF THE WATER HEATER

From whichever position the gas control knob is in, turn it to the right to the ● position. This will automatically cut off the supply of gas to the pilot and the burner.

• PRECAUTIONS TO BE TAKEN AGAINST FROST AND FREEZING CONDITIONS

During cold spells, if your appliance is located in a place exposed to frost and freezing conditions, it must be drained down in the following way:

- Turn off the appliance's water inlet stopcock.
- Turn on all hot water taps.
- Turn temperature selector fully anticlockwise.
- Remove the drain plug (no. 4) to let the water stored inside the appliance out.
- When this operation has been completed, turn off the hot water taps and put the drain plug back.

To start up the appliance again, open its water inlet stopcock.

• MAINTENANCE RECOMMENDATIONS

The appliance must be checked for safe operation annually, regardless of frequency of use. This refers principally to the correct combustion of the main burner and pilot. Maintenance should only be carried out by a qualified and competent service engineer. Please refer to section 2.4 of this manual.

• CHECKING FOR SAFE OPERATION

In addition to any annual service by a competent person, the user should carry out the following checks periodically an especially after any period of disuse.

• PILOT BURNER

Look through the pilot window and check the pilot flame is blue. There should be no yellow colour or laziness.

• MAIN BURNER

Look through the pilot window when the hot tap is open and the boiler is running. The burner flames should be all blue with no yellow/white colour or laziness.

If you see any yellowness or laziness in the flames do not use the appliance and call a service engineer. The burners will almost certainly be blocked by dust/fluff or insect matter and further use will cause sooting up leading to a dangerous situation and expensive repair.

• OTHER INDICATIONS

- Never tamper with any presealed unit.
- There is a danger of burning yourself if you touch the area around the ignition window. We recommend that you avoid touching this area.
- This appliance has a device to control the removal of combustion gases. If there are any disruptions in the removal of these gases, the device immediately cuts off the supply of gas to the burner.

To restart the appliance, you must wait at least 10 minutes before lighting the pilot light, as described earlier.

If these interruptions occur repeatedly, call for service.

A.2.- TECHNICAL INSTRUCTIONS FOR INSTALLATION ENGINEERS

A.2.1. Technical information

- Shape and outer dimensions

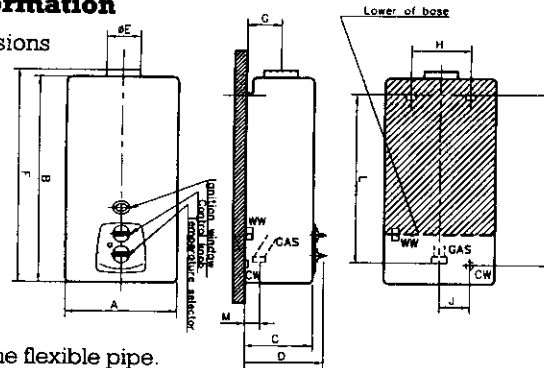

* WW, go connecting with one flexible pipe.

	A	B	C	D	E	F	G	H	I	J	L	M
G111E	350	680	230	265	110	700	115	244	596	50	588	45
D51B	266	573	190	225	84	593	97	125	342	50	334	45

• SPECIFICATIONS

- Available calorific power

MODELS	D51B	G111E
Maximum	8,7 kW (125 Kcal/min.)	19,2 kW (275 Kcal/min.)
Minimum	5,2 kW (75 Kcal/min.)	11,4 kW (165 Kcal/min.)

- Output in terms of a p.c.i. over 84%

• HOT WATER DELIVERY

The figures quoted are for the appliance at normal operating pressure at minimum and maximum selector settings.

NOTE: Temperatures are in degrees rise above ambient.

MODELS	TEMPERATURE SELECTOR SETTING			
	OPEN		CLOSED	
	Water flow rate	Δt	Water flow rate	Δt
D51B	5 Litres/min.	25° C	2,5 Litres/min.	50° C
G111E	11 Litres/min.	25° C	5,5 Litres/min.	50° C

• OPERATING PRESSURE:

- Minimum 1 bar
- Maximum 10 bar
- Water inlet pressure with the appliance working at normal pressure.

• GAS CONSUMPTION

TYPE OF GAS (Standardized gases)	GAS FLOW AT 15° C and 760 mm Hg		GAS PRESSURE AT APPLIANCE INLET (mbar)
	MODELS		
	D51B	G111E	
Butane	0,8 Kg/h.	1,76 Kg/h.	28
Propane	0,8 Kg/h.	1,76 Kg/h.	37

• BURNER PRESSURE

Butane gas: 27.6 mbar

Propane gas: 36.3 mbar

• PIPE WORK DIAMETERS AND CONNECTION SIZES

PIPE WORK		CONNECTION SIZES
	BUTANE PROPANE	3/8 or 15 mm.
	Inlet (cold)	15 mm.
	Outlet (hot)	15 mm.
Flueway	D51B	Ø 83 mm.
	G111E	Ø 110 mm.

• DESCRIPTION AND OPERATION

These gas water heaters are equipped with:

- A stainless steel burner which can operate with Butane-Propane.
- A pilot which can be adapted to operate with Butane-Propane. It can be taken apart easily for cleaning. Ignition is by piezoelectric spark ignition.
- A fully automatic progressive ignition system which needs no adjusting. This prevents any black smoke being given off during the ignition process.
- A thermocouple safety valve which shuts off the gas supply to both pilot and main burner in the event of accidental flame failure.
- An inter-ignition valve which cuts off the supply of gas to the burner during the pilot ignition process, even if there is water circulating through the appliance.
- A total shut-off valve which shuts off the supply of gas to the burner and the pilot, even during the response time before the safety valve closes.
- A water shortage safety valve which adapts the supply of gas to the burner to the circulation of water through the appliance.
- A gas economy feature which enables the supply of gas to the burner to be reduced by up to 60%, to adapt the operation of the appliance when the ambient temperature of the water supply is high.
- An automatic water flow regulator.
- A temperature selector.
- A heat exchanger made from pure electrolytic copper.
- A draught diverter hood.

- A set of water inlet and outlet and gas inlet accessories, which make it easier to connect the heater to the mains water and gas supplies.

OPERATION

Once the appliance has been turned on following the indications given in section A.2.3. «Instructions for starting up the appliance» gas is supplied to the burner whenever a hot water tap is turned on.

What actually happens is that when a hot water tap is turned on, water starts to circulate through the appliance and a valve, controlled by a diaphragm device which operates by differential pressure, opens, supplying gas to the burner.

When the hot water tap is turned off, the water pressure in the appliance is interrupted, as is the differential pressure in the control device, automatically shutting off the supply of gas to the burner.

Whilst the appliance is in operation, even if there are pressure fluctuations in the mains supply, the temperature of the water is maintained at all times at the temperature preset with the «temperature selector» thanks to the action of the «automatic water flow regulator».

DATA PLATE D51B

MORCO INSTANTANEOUS GAS WATER HEATER		 0099	
Mod. No:	D 51 B		
Gas Type:	G30	28mbar	30mbar
	G31	37mbar	30mbar
Type:	B11BS	Cat. I ₃ +	Cat. I ₃ B/P
Qn (Hi)	11,1 kW		
Qm (Hi)	7 kW		
Pn	8,7 kW		
Pw	10 bar		
Cat.		I ₃ +	I ₃ B/P
Country/Pays:		GB / FR / IE / IT / ES / BE	NL
USE ONLY IN WELL VENTILATED ROOMS NOT TO BE INSTALLED IN BATHROOMS			
Manufactured in Spain exclusively for: MORCO PRODUCTS LIMITED 59 Beverley Road HULL ENGLAND			

DATA PLATE G111E

MORCO INSTANTANEOUS GAS WATER HEATER		 0099	
Mod. No:	G 111 E		
Gas Type:	G30	28mbar	30mbar
	G31	37mbar	30mbar
Type:	B11BS	Cat. I ₃ +	Cat. I ₃ B/P
Qn (Hi)	22,8 kW		
Qm (Hi)	13,7 kW		
Pn	19,2 kW		
Pw	10 bar		
Cat.		I ₃ +	I ₃ B/P
Country/Pays:		GB / FR / IE / IT / ES / BE	NL
USE ONLY IN WELL VENTILATED ROOMS NOT TO BE INSTALLED IN BATHROOMS			
Manufactured in Spain exclusively for: MORCO PRODUCTS LIMITED 59 Beverley Road HULL ENGLAND			

OPERATING DIAGRAM

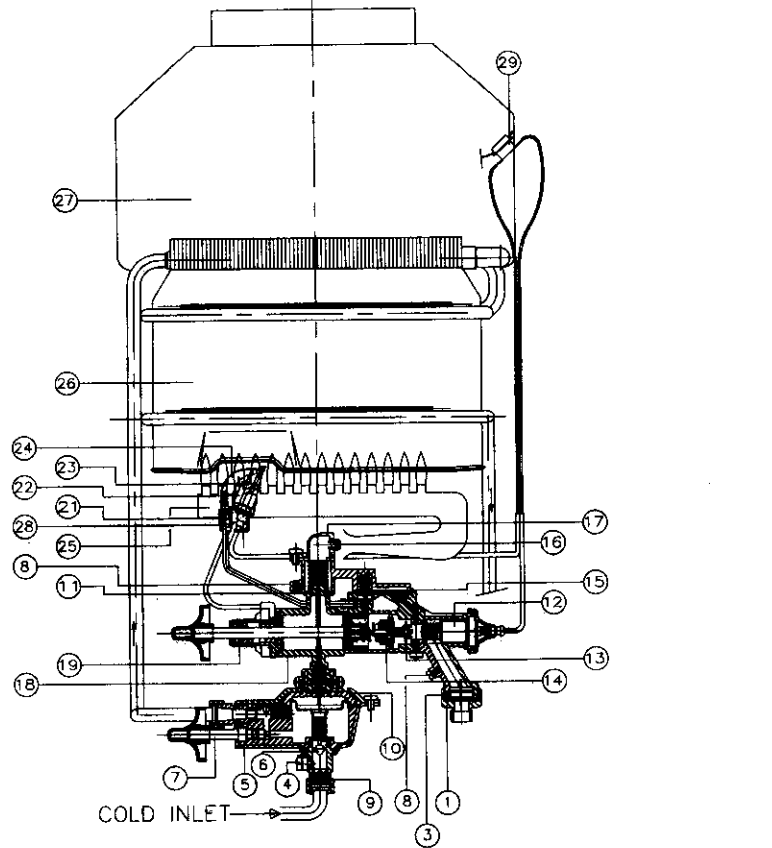

- | | |
|------------------------------|--|
| 1-GAS SUPPLY CONNECTION | 16-BURNER JET |
| 3-GAS FILTER | 17-DISTRIBUTOR |
| 4-DRAIN PLUG | 18-MAIN BODY |
| 5-LOWER BODY | 19-BODY COVER |
| 6-WATER FLOW REGULATOR | 21-PILOT JET |
| 7-SELECTOR SCREW | 22-PIEZOELECTRIC SPARK IGNITER HEAD |
| 8-PRESSURE TAP | 23-THERMOCOUPLE HEAD |
| 9-WATER FILTER | 24-PILOT HEAD |
| 10-UPPER BODY | 25-BURNER |
| 11-WATER SAFETY VALVE | 26-HEATING BODY |
| 12-COMPLETE MECHANISM | 27-DRAUGHT DIVERTER HOOD |
| 13-POWER SELECTOR | 28-PILOT SECURING NUT |
| 14-INTER-IGNITION VALVE | 29-COMBUSTION PRODUCTS DISCHARGE SAFETY DEVICE |
| 15-PILOT EXTINGUISHING VALVE | |

A.2.2.-INSTALLATION INSTRUCTIONS

•RECOMMENDATIONS

For the user

This appliance must be installed, adjusted or adapted for use with another type of gas only by a qualified and competent person.

It is both the quality as well as the correct installation which will ensure that your heater works properly.

For the installation engineer

A.2-2-A RELATED DOCUMENTS

The following British Standards, Codes of Practice and other Regulations must be observed in the installation of the water heater.

The Gas Safety Regulations (Installation and Use) 1996

The Model Water Byelaws

Byelaws of the Local Water Undertaking

The Building Regulations (Permanent Buildings) England and Scotland

BS 5482 Part 1 Installations in Permanent Dwellings

BS 5482 Part 2 Installations in Caravans and Non-Permanent Dwellings

BS 5482 Part 3 Installations in Boats

BS EN 1949 Installation of LPG System for Habitational Purposes in Leisure Accommodation Vehicles

EN 721 Leisure Accommodation Vehicles-Ventilation Requirements

Location:

The water heater requires a plentiful supply of fresh air for correct operation. Fixed ventilators, or air inlets, should not be obstructed.

Do not install the water heater in a location where incomplete combustion is foreseeable.

IE In bathrooms or bedrooms unless specifically allowed by national legislation.

The minimum ventilation free areas are stated in this Manual and must be observed.

The water heater must be fixed to a load bearing wall in a vertical plane.

The water heater should not be installed adjacent to combustible materials either above or at the sides or rear, if the temperature of those surfaces could otherwise exceed 65°C based on an ambient temperature of 15°C. In such cases a heat shield must be installed in the form of a fabrication from sheet metal mounted away from such surfaces to allow a minimum air gap of 25 mm.

• COMBUSTION GAS REMOVAL

Flue: A draught diverter is fitted to the top of the water heater. The nominal flue size is 83 mm. (D51B) and 110 mm. (G111E). In exposed situations, twin-walled flue pipe should be used. A minimum length of vertically rising flue of 600 mm must be provided to ensure the water heater's products of combustion are completely evacuated. If single wall flue pipe is being used which has to pass through combustible materials, provide a metal sleeve of 115 mm diameter which allows an air gap of 25 mm.

The flue shall not run into chimneys for removing combustion products from solid or liquid fuels. Flue pipes and terminals should comply with BS 715. Terminals shall not be sited within 300 mm of a ventilator or open window. In the U. K full details of flueing requirements are given in BS 5440 Part 1.

The flow rate of the combustion gases is 12.75 m³/h (G-30 and G-31), and the temperature of the combustion gases at the exit to the draught diverter hood is 165°C (Model D51B).

The flow rate of the combustion gases is 28 m³/h (G-30 and G-31), and the temperature of the combustion gases at the exit to the draught diverter hood is 190°C (Model G111E).

This appliance is fitted with a device to monitor the removal of combustion gases, which cuts off the supply of gas to the burner, thereby turning off the appliance.

The function of this device is to prevent the combustion gases from getting into the premises where the appliance is installed when there are problems with their removal due to adverse weather conditions or incorrect draught in the flueway. It is a safety device to ensure that the combustion gases are removed properly. This device should never be taken out of service, as this would mean a lack of safety in the correct operation of the appliance.

Whenever any repairs are made to this device, only original parts should be fitted. A check should always be made to ensure that the appliance works correctly. The procedure is as follows:

- a) Turn the appliance on.
- b) If air does not blow back through the flueway due to bad weather conditions (too much wind), the control device should not stop the appliance, at least during 30 minutes of continuous operation.

If this test is carried out satisfactorily, the appliance is in perfect operating condition.

If the appliance repeatedly turns off, this means that the combustion gases are not being removed correctly. The problem should be resolved by taking the appropriate steps.

• AIR SUPPLY FOR COMBUSTION

Air Requirements: Reference is made to BS 5482 (BS EN 1949) and EN 721 covering ventilation requirements for permanent dwellings, caravans and boats.

Fixed ventilation should be provided to avoid draughts as far as possible and without impairing the free area of ventilation, even in adverse weather conditions.

All permanent openings for ventilation should be designed to prevent the entry of vermin. Where screens are provided, they should not have apertures of less than 6 mm or greater than 9 mm in any direction, and they should be accessible for cleaning. Fine mesh screens should be avoided as they are liable to become blocked with dust.

The location of vents and the method of cleaning them should be stated in the Owners Handbook (Caravans and Boats).

As a guide, the minimum effective free area of vents is stated below in connection with this water heater. Additional appliances burning gas in the same area would require additional air requirements.

1. If a D51B or G111E is installed in an enclosed space in a Caravan Holiday Home the required ventilation is that as specified in BS 5482 part 2, ie 10 cm² per kilowatt input rating divided between high and low. So the high and low vents should be 55.5 cm² for D51B and 114 cm² for G111E.
2. Where a D51B is installed in an open bottomed cupboard in a Caravan Holiday Home, ie in a kitchen, the ventilation requirement is as stated in BS 5482 part 2. (EN 721).

A.2.2.B PUTTING THE APPLIANCE INTO SERVICE

Checks:

Check that the mains water and gas supplies meet the specifications given on the appliance's technical specifications plate. Take special care to ensure that the water and gas pressures are correct. Also make sure that the bottle regulator is large enough to allow sufficient gas to be supplied to the appliance, bearing in mind the gas consumption of other appliances on the same meter.

• FIXING THE APPLIANCE

To do this you only need to remove the cover. Proceed as follows:

- Remove the control knobs.
- Remove the screw securing the front of the cover, hidden by the temperature selector control button.
- Remove the screws (2) which secure the cover to the base, at the bottom.
- Remove the cover from the lugs which secure it to the top of the base.

Having selected a location for the water heater in accordance with the requirements set out in this Manual, the water heater should be fixed to the wall using the mounting holes on either side of the base plate.

• PUTTING THE APPLIANCE INTO SERVICE

- Before connecting up the appliance, it is necessary to purge the water and gas pipe work thoroughly, in order to remove filings and other waste material.

- Connect the gas intake to the appliance, ensuring that the seal is in place.
- Connect the water intake and outlet to the appliance.
- Ensure that all the seals are properly fitted.
- Replace and secure the appliance's cover.
- Replace the control knobs.

• **WATERTIGHTNESS OF THE WATER CIRCUIT**

Open the water inlet into the appliance by fully turning on the water inlet tap to the appliance. Purge the air from the water pipes by turning on all the hot and cold water taps. Then turn off these taps and check the watertightness of the various connectors.

• **GASTIGHTNESS OF THE GAS CIRCUIT**

Connect a manometer to the pressure nipple (Number 8 on Operating Diagram) and carry out a gas soundness test. There should be no leakage.

• **STARTING UP THE APPLIANCE AND FINAL CHECKS**

Start the appliance by following the directions given in section 1, «Instructions for users», checking that the appliance is working correctly. Pay special attention to the colour of the flames ensuring there is no yellowness which would indicate burner venturis blocked by insect matter.

Check the operating pressure of the burners using the pressure nipple located on the left hand side of the gas body assembly (as viewed from the front). The operating pressure must not be less than 2.5 mbar below that specified in this Manual.

These gas water heaters are set in the factory for use with the gas they are intended to burn. The gas for which each appliance is set is indicated on the packing and on the cover of the heater itself.

Note: The jets to be used with the type of gas for which the appliance is intended will be supplied from the factory. Their diameters correspond to the following sizes:

MODELS	GAS	Ø in mm.:	
		BURNER	PILOT
D51B	G.P.L.	0,72 (6)	0,19
G111E	G.P.L.	0,72 (12)	0,19

A.2.3.-LOOKING AFTER THE APPLIANCE

• PRECAUTIONS

- Against furring up

If the appliance is installed in an area with very hard water, with time, the following may occur:

- a fall in the hot water temperature, or
- a reduction in the hot water flow.

This means that the heat exchanger has furred up, giving rise to the aforementioned consequences.

To reduce this effect and given that the amount of furring up is proportional to the water outlet temperature, we recommend that the temperature required is obtained by setting the temperature selector control and not by mixing cold water with the hot water from the heater.

Note: Defurring/descaling should be carried out using a proprietary descaling agent or dilute hydrochloric acid.

• MAINTENANCE

• MINIMUM ANNUAL MAINTENANCE

Gas water heaters are rugged pieces of equipment which are designed to work for a long time with minimum maintenance requirements. The only regular maintenance required is the (annual) cleaning of the heating body and the burner. If the appliance is installed in a caravan or boat is essential this is done at the beginning of each season.

• CLEANING THE BURNER

To carry out the annual cleaning of the burner, proceed as follows:

- Turn off the gas supply, remove the cover and take out the burner.
- Clean the surface of the burner heads gently with a brush. Then blow through them to remove any particles of dust loosened during the brushing operation. Check the venturis for contamination from insects and spiders webs.

• CLEANING THE HEATING BODY

To carry out the annual cleaning of the heating body, proceed as follows:

- Turn off the gas supply.
- Turn off the supply of water to the appliance by turning off the appliance's water inlet tap.
- Turn on all the hot water taps to empty all the pipes.
- Remove the heating body and clean it by gently brushing the radiator fins. Particles of dirt can be removed by using a jet of cold water.

• CLEANING THE PILOT

If after the appliance has been in use for some time, the pilot light flame is yellow and the safety valve takes a long time to open, this means that the pilot is partially blocked by particles of dirt which may come either from the gas (work on the gas pipes, etc) or from the local atmosphere.

When the pilot is working normally the flame should be a stable blue- coloured cone shape. To clean the pilot, proceed as follows:

- Turn off the gas supply, remove the front cover. Remove the pilot burner by first undoing the screw which holds it in place, then by slackening the supply pipe nut and unscrewing the pilot jet.
- Blow through the pilot pipe to remove the dirt accumulated inside.
- Clean the jet by brushing its surface gently. Then blow through the hole. Do not use wire.
- Replace the pilot, ensuring that the seals are properly fitted.

A.2.4. SYMBOLS

The meaning of the symbols used on the appliance and on the packing is as follows:

Cat: Appliance category

Qn : Nominal gas flow rate according to Hi

Qm: Minimum gas flow rate according to Hi

Hi: Net calorific value

A.2.5. WARRANTY

The water heater is guaranteed against manufacturing defects for one year from first commissioning. However the guarantee is subject to proof of commissioning in accordance with the gas safety (Installation and Use) act 1994. The guarantee does not cover defects caused by lack of maintenance see section 2.4.

Manufactured in Spain by Fagor Electrodomésticos.

Distributed in U.K. by:

MORCO PRODUCTS LTD

59 Beverley Road

HULL HU3 1XW

ENGLAND